

Meadow Creek®

PR60GT

Overall Dimensions: 117"L x 41½"W x 45"H

Grate Dimensions: 24" x 58", Custom S.S. Wire Grid ½" Spacing

2nd Tier Grate Dimensions: 22" x 58"

Net Weight: 500 lbs.

Shipping Weight: 625 lbs.

Product Details: Metal Thickness 13 Gauge • Approx. 82,000 BTU

Standard	Standard Options	Standard Options
Stainless Steel Grate	Charcoal Insert, 13 Gauge	Charcoal Grilling Pan
Thermometer	Vinyl Cover	Fire Extinguisher Mount
Grease Drip Pan	Chip Tray, 1' x 2'	Certificate of Origin
2" Ball Hitch	2nd Tier Grate, 8" High	
Safety Chains	Doors In Lid	
Rubber Torque Axle	Spare Tire w/Mount	
Highway Wheels	30 lb. or 43 lb. Propane Tank	
E.Z. Lube Bearing	Rib Rack	
Wheel Jack		
L.P. Gas Tank Mount		
Gas Safety Valve w/Pilot		
8" Wheel with 18" Tires		
Manufacturer's VIN Plate		
Trailer Lights, 4 Prong Flat		

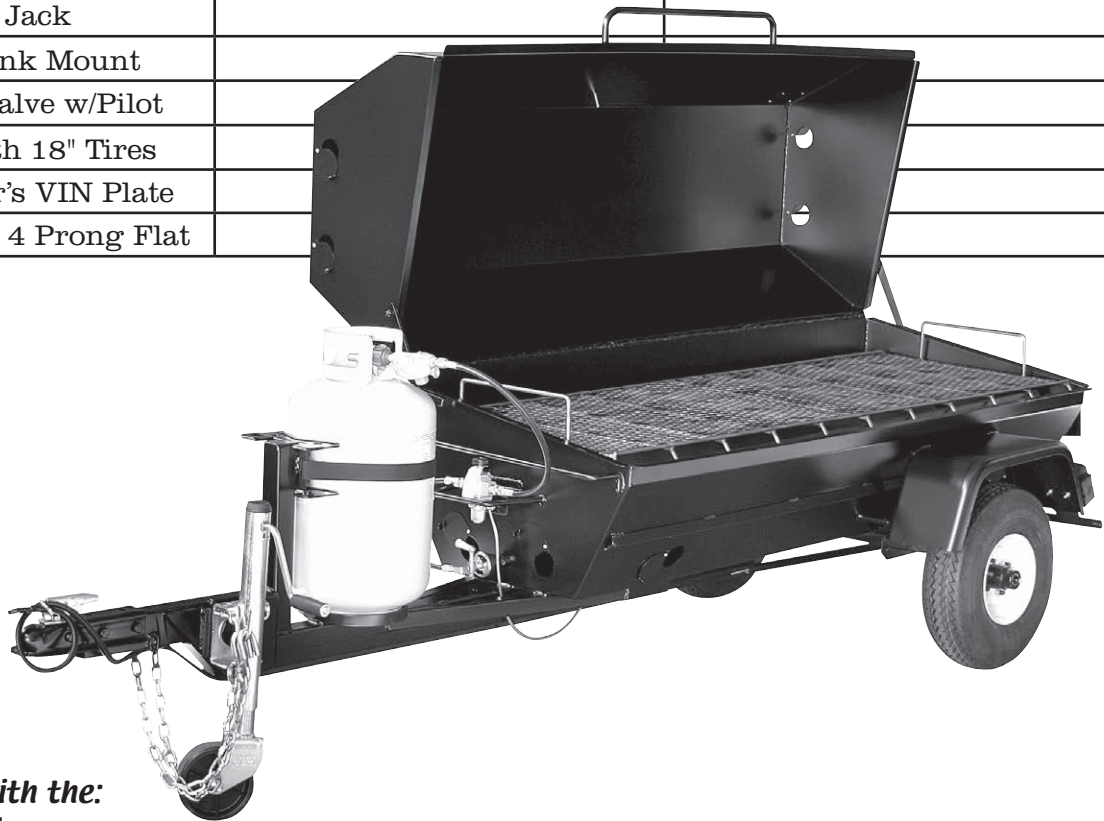

Recommended with the:

PR60G & PR60GT

This unit is gas fired. A 30 lb. tank will do approximately 15 hours of cooking at a temperature of about 300 degrees.

Meadow Creek Welding uses only food grade T-304 stainless steel in the fabrication of parts identified as "stainless steel" that will contact food under normal use. This includes, but is not limited to: Grates, racks, shelving, work surfaces and complete units constructed primarily of stainless steel and sold using that description.



PR60GT

